

THIS DRAWING IS UNPUBLISHED. RELEASED FOR PUBLICATION, 19 .  
 © COPYRIGHT 19 BY AMP INCORPORATED. ALL RIGHTS RESERVED.

LOC	DIST	REVISIONS			
P	LTR	DESCRIPTION	DATE	DWN	APVD
AF	50	K	REV PER OG3A-0679-03	27OCT03	JR DD

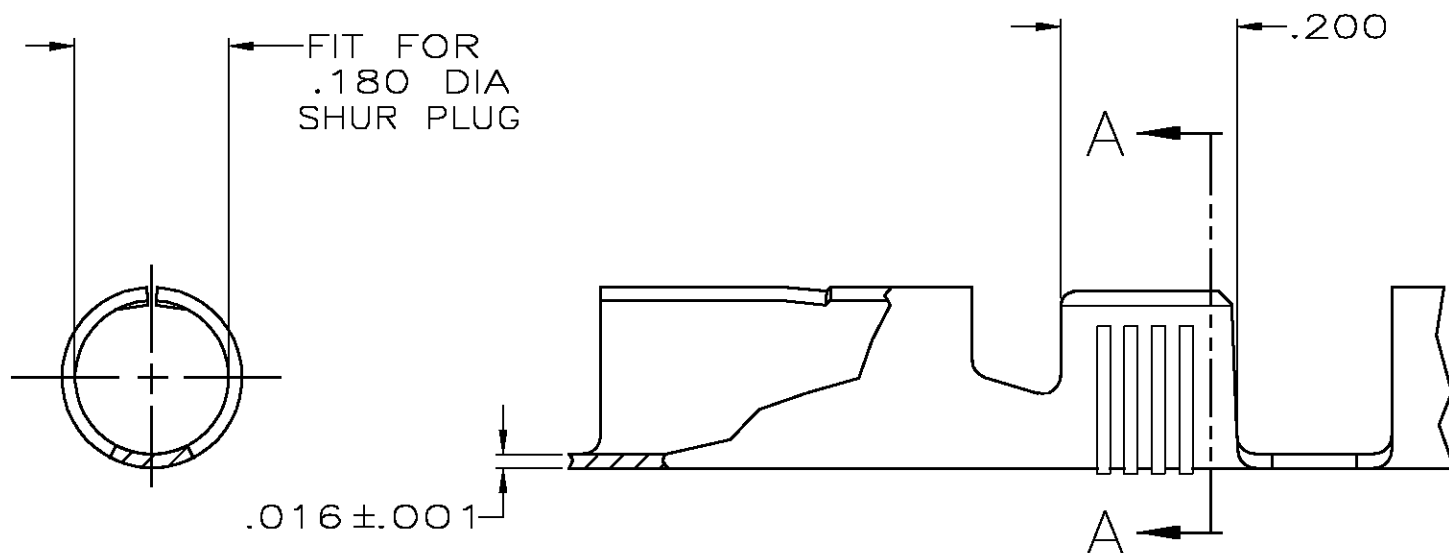

- 1 CONTINUOUS STRIP ON REELS.
- △2 .000080 MIN TIN PLATE.
- △3 .000080 MIN TIN PLATE OVER .000050 MIN NICKEL UNDERPLATE.
- △4 .000150 MIN NICKEL PLATE
- △5 PRELIMINARY - NOT FOR PRODUCTION

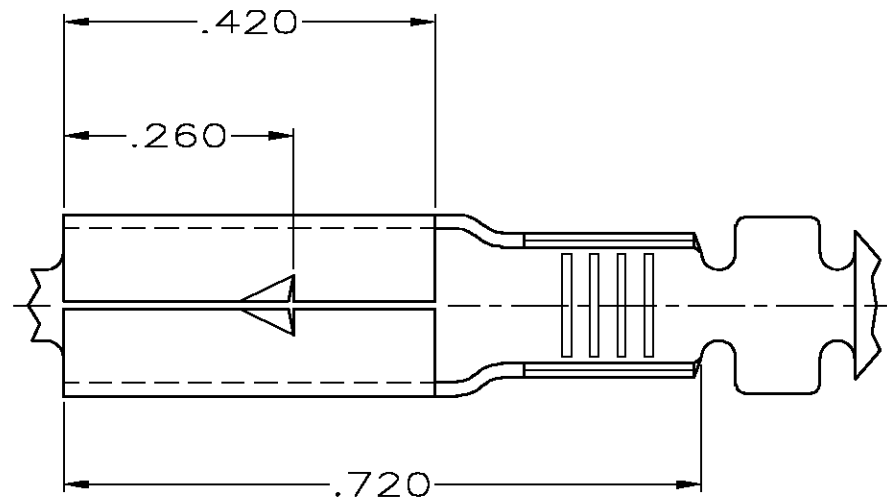
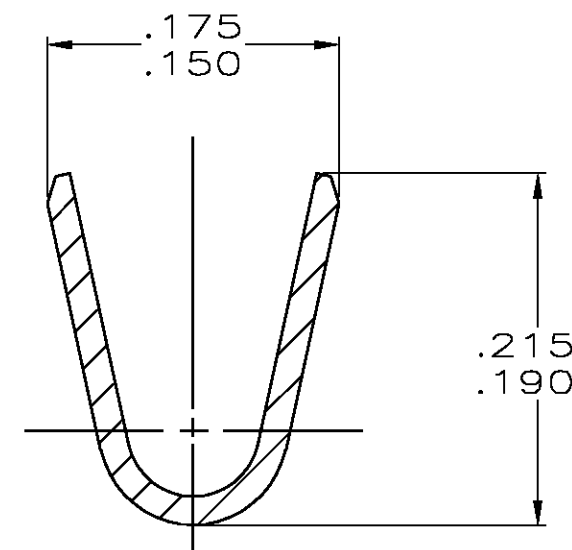

△4	14-10 AWG	△5	42868-4
△3	14-10 AWG		42868-3
△2	14-10 AWG		42868-2
-	14-10 AWG		42868-1
FINISH		WIRE RANGE	
		PART NUMBER	

DIMENSIONS:		TOLERANCES UNLESS OTHERWISE SPECIFIED:	
INCHES			
	0 PLC	±-	
	1 PLC	±-	
	2 PLC	±-	
	3 PLC	±.010	
	4 PLC	±-	
	ANGLES	±-	
MATERIAL		FINISH	
4M BRASS		SEE TABLE	

DWN	12JUL2001	AMP Incorporated	
MICHAEL S. FEHER		Harrisburg, PA 17105-3608	
CHK	12JUL2001	<b>AMP</b>	
DONALD DECKER		NAME	
APVD	12JUL2001	RECEPTACLE, SHUR PLUG,	
DONALD DECKER		.180 DIA	
PRODUCT SPEC		SIZE	RESTRICTED TO
-		A3	-
APPLICATION SPEC		CAGE CODE	DRAWING NO
114-2017		00779	42868
WEIGHT		SCALE	SHEET
-		5:1	1 OF 1
CUSTOMER DRAWING		REV	K